



tel.: +359 2 42 41 325
e-mail: site@simonacards.bg
www.simonacards.com

Design requirements for plastic cards, key-cards or playing cards

Artwork

We accept files in the following formats: PDF (Adobe Acrobat), AI (Adobe Illustrator), PSD (Adobe Photoshop). Other formats will be accepted if the artwork is prepared correctly: JPG, TIFF, GIF or BMP.

Colors

All files should be supplied in CMYK (Cyan, Magenta, Yellow and Black) Color Mode or with Pantone colors (Solid Coated). All RGB elements or files will be converted to CMYK.

In case of printed material needs to match other printed material's color or previous printed colors we will need a printed sample of the required colors.

Fonts

Please forward all the fonts that you have used in your artwork. It is preferred that wherever possible all fonts to be converted to outlines/curves.

Images

The preferred format for any raster graphics is TIFF although we can accept most standard formats JPG, GIF etc. These should be supplied at a minimum of 300 dpi. Anything below this can result in lower quality reproduction of your card when it comes to printing.

It is preferable to use vector elements rather than raster images. It is important especially for companies' logo and text. Please convert all fonts to outlines.

Adobe Illustrator vCS5 or Lower

We accept EPS and AI files. Please convert all fonts to outline /curves and embed all images.

Adobe Photoshop vCS5 or Lower

Please prepare the artwork no lower than 300 dpi. The file could be saved as TIFF or PSD format.

CoreIDRAW v15 or Lower

The file could be saved as CoreIDRAW or EPS file. Please convert all fonts to curves and make the artwork no lower than 300 dpi.

Standard Plastic Card Dimensions

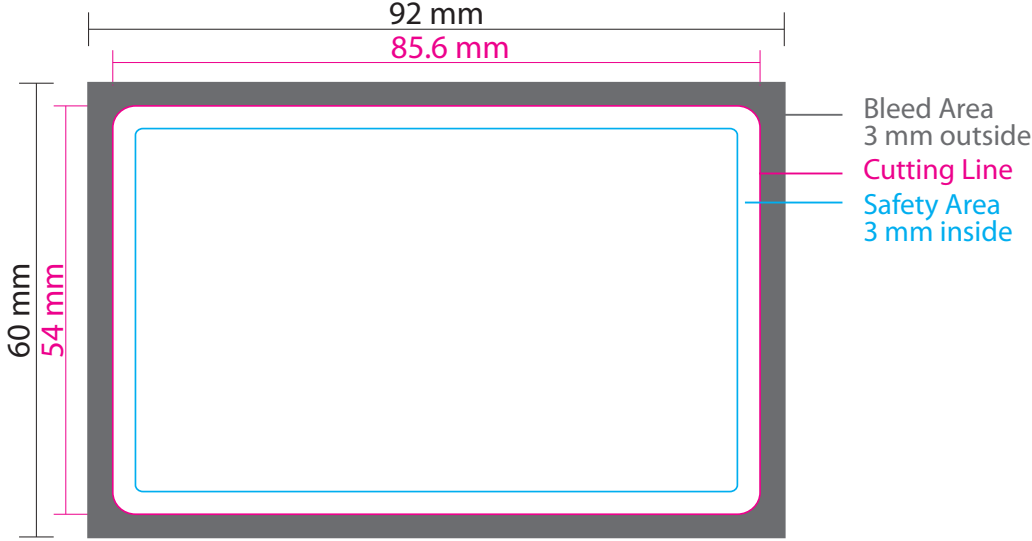

Finished card dimensions are indicated by the Cutting line (85.6 x 54 mm)
Bleed area (GREY area) must be extended 3mm outside the finished card dimensions. The card design images should therefore extend to 92 x 60mm (i.e designs can “bleed”).
All important design elements need to be kept in the Safety Area (BLUE area), 3mm within the finished cards dimensions, in order to avoid problems with cutting.

Magnetic Stripes

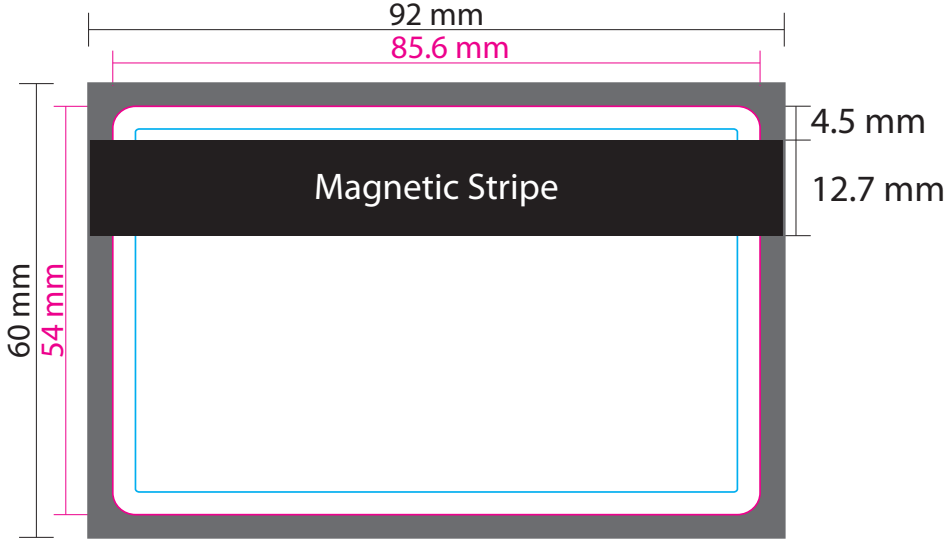

The position of the magnetic stripe should be placed 4.5 mm off the cutting line.

Signature panels

Signature panel can be in any size or shape.



Embossing

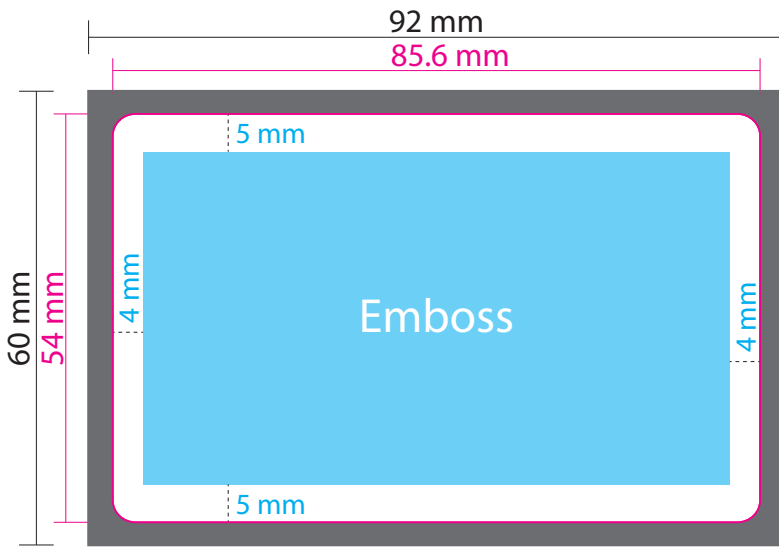

The embossing affects the other side of the card, so the design should be carefully appointed to the desired emboss personalization.

The possible embossing area is marked in blue.
We use standard embossing font - STANDARD GOTHIC.
There are two available sizes for numbers: 3mm and 5mm (OCR 7B) height. For letters (capitals), one size is available - 3mm height.

Holes

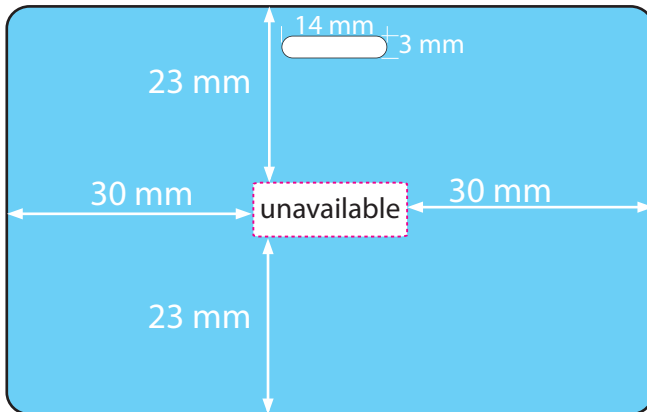

Holes can be positioned horizontally and vertically within the Blue area.

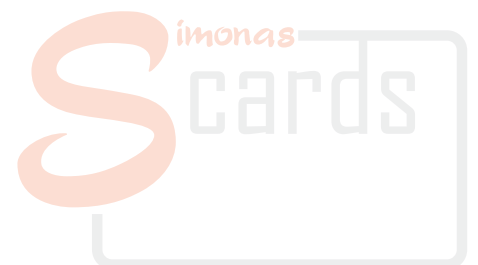
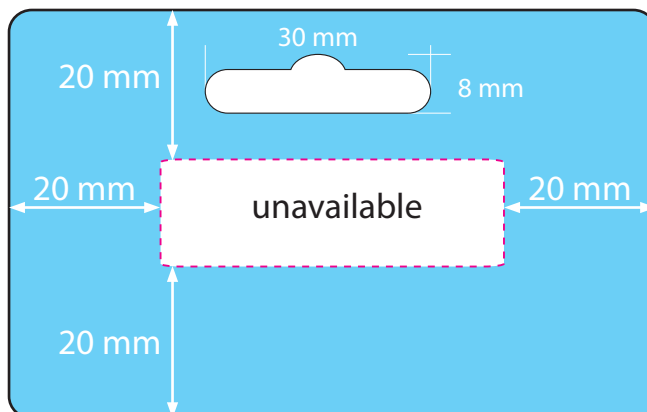
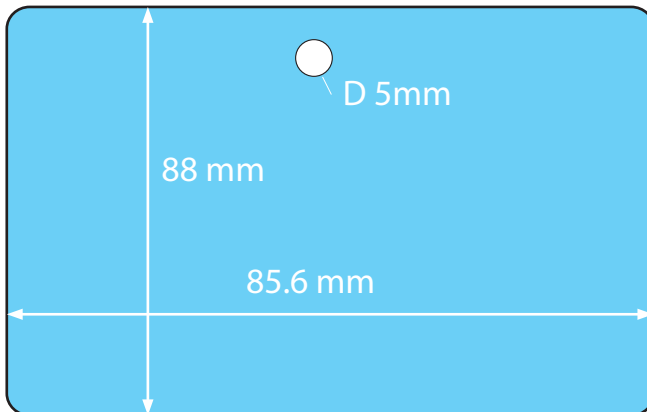

Hot stamping, scratch off panel, hologram

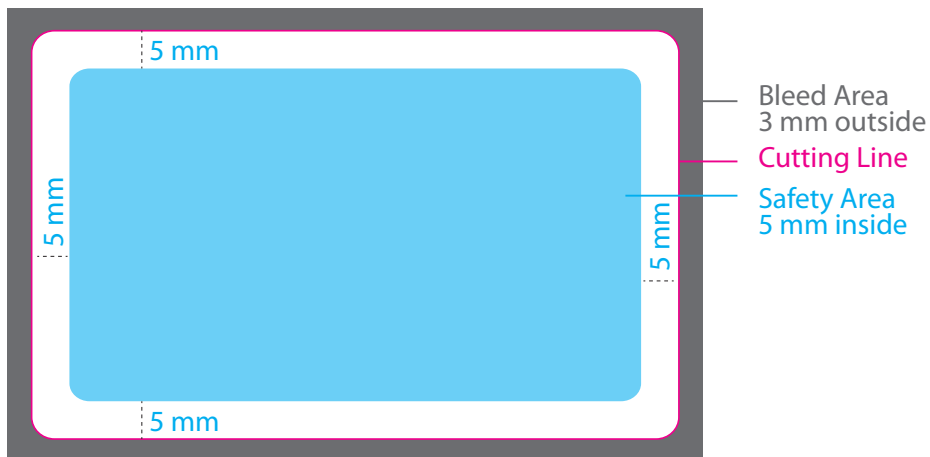

It is necessary hot stamp, scratch off panel and hologram image to be designed in the Safety area (BLUE area), which is 5 mm inside the card from all sides.
 Hot stamp design should be prepared as additional vector graphic, marked with different color .

Plastic key tag card / key fob card dimensions

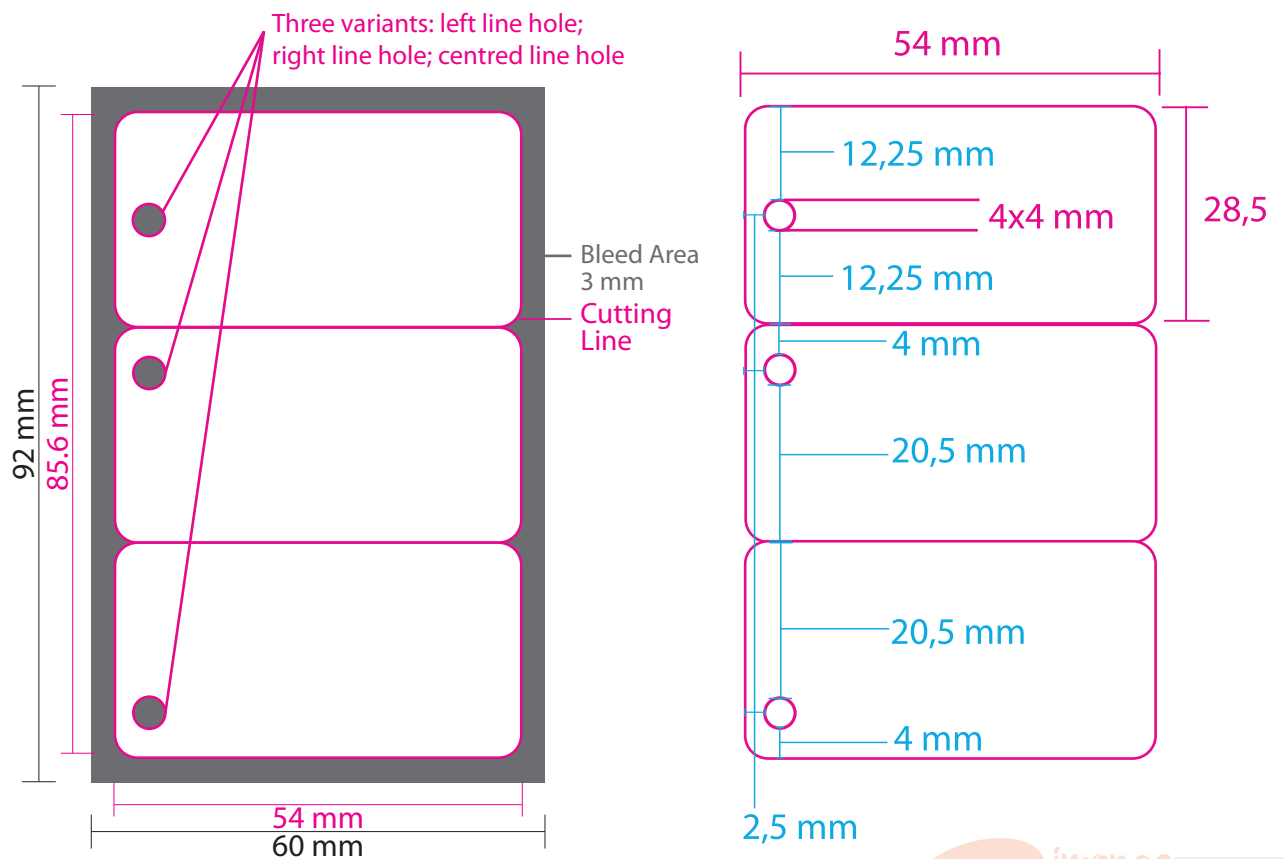

Standard POKER Playing Card Dimensions

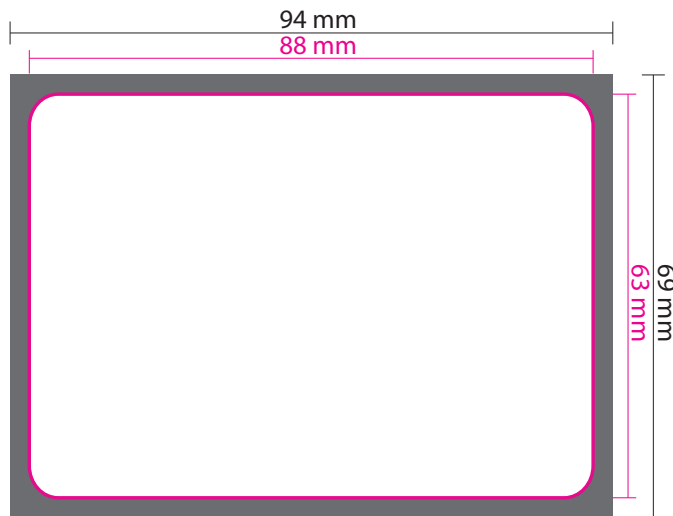

Finished POKER card dimensions are indicated by the Cutting line (88 x 63 mm)

BRIDGE Playing Card Dimensions

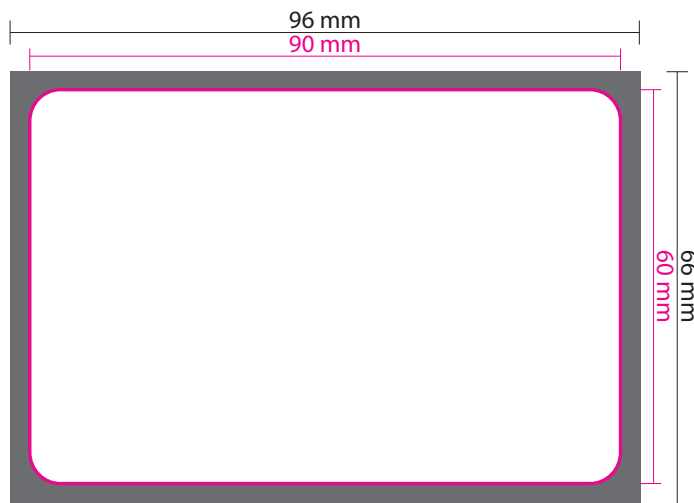

Finished BRIDGE card dimensions are indicated by the Cutting line (90 x 60 mm)